

SPX 527 CDH

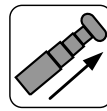

5940 lbs



11'2" - 39'8"

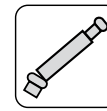

6'11" - 13'5"

	7920 lbs	-	66 lbs	JIB600H: 484 lbs	
	13'10"x3'7"x6'5"		1.24 MPH		25°
	5940 lbs		6.68 PSI		
	<p>: 3 cylinders water cooled diesel, ISUZU mod. 3CB1, 2 rpm levels, EPA TIER 4 Motore: 3 cilindri diesel raffreddato a liquido, ISUZU mod. 3CB1, 2 livelli di regime, EPA TIER 4 Motor: Wassergekühlter 3 Zylinder Diesel Motor, ISUZU mod. 3CB1, 2 rpm, EPA TIER 4 Motor: Diesel 3 cilindros con refrigeración por aire, ISUZU mod. 3CB1, 2 niveles rpm, EPA TIER 4 Moteur: Diesel 3 cylindres, refroidissement à eau, ISUZU mod. 3CB1, accélérateur à 2 niveaux, EPA TIER 4</p>				
	4kW 240V-60Hz-AC 1F		110 lbs		
<p>1 base and 4 telescopic sections high-tensile structural steel. All sections synchronized and full power. Braccio Telescopico: 1 braccio principale e 4 telescopici in acciaio strutturale ad alta resistenza. Sfilo completamente idraulico e sincronizzato. Teleskopausleger: 1 Hauptausleger + 4 Hochwiderstand Stahl Teleskopausleger. Voll hydraulischer und teleskopierbarer Ausleger. Pluma Telescópica: 1 pluma principal y 4 telescópicas en acero de alta resistencia. Elementos sincronizados e hidráulicos. Flèche Telescopique: 1 flèche principale et 4 télescopiques en acier à haute résistance. Éléments synchronisés et hydrauliques.</p>					
	360° 1 rpm		-2°/80° 35"		
	11'2" - 39'8" 40"		1980 lbs - 196' - Ø3/8 in SPX527CDH+: 98 ft/min		

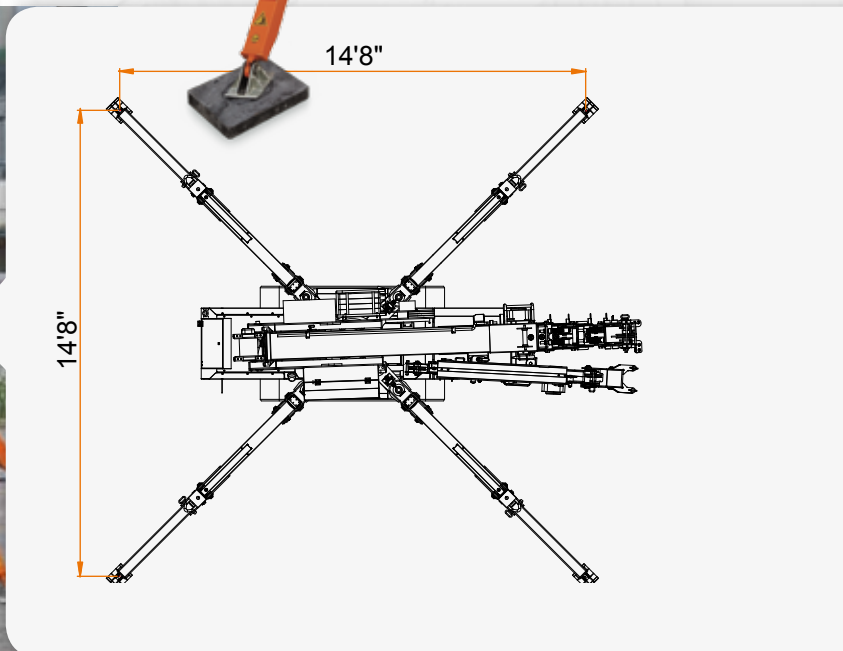

SPX 527 CDH

