

UP & DOWN
LIFTING SOLUTIONS

MRT 2550

Previlege Plus Series 2
Rotating Telescopic Handles



UP & DOWN LIFTING SOLUTIONS • 335 Waydom Drive, Ayr Ontario, N0B1E0
Email: rentals@upanddown.ca • Tel: 519-588-5438 or 519-575-5438 or 1-844-401-9723

www.upanddown.ca



MRT 2550 PRIVILEGE PLUS SERIES 2 ROTATING TELESCOPIC HANDLERS

TECHNICAL DATA

Description	Value
Lift Capacity with Forks (kg):	11,000 lbs. (5000)
Lift Capacity with Winch (kg):	11,000 lbs. (5000)
Max. Lift Height (m):	81'0" (24.7)
Capacity at Max. Lift Height (kg):	4,400 lbs. (2000)
Max. Forward Reach (m):	70'3" (21.4)
Cap. at Max. Forward Reach (kg):	900 lbs. (400)
Approximate Weight (kg)	41,667 lbs. (18900)
Length - Less Forks (m)	25'9" (7.84)

DIMENSION REFERENCE DIAGRAMS

MM	Value
C	25'9" (7840)
D	17'6" (5350)
E	3'9" (1150)
F	10'0" (3050)
G	3'9" (1150)
H	13.8" (350)
J	10'0" (3050)
M	8'2" (2490)
O	18'3" (5555)
V	3'1.4" (950)
Y	12°
Z	105°

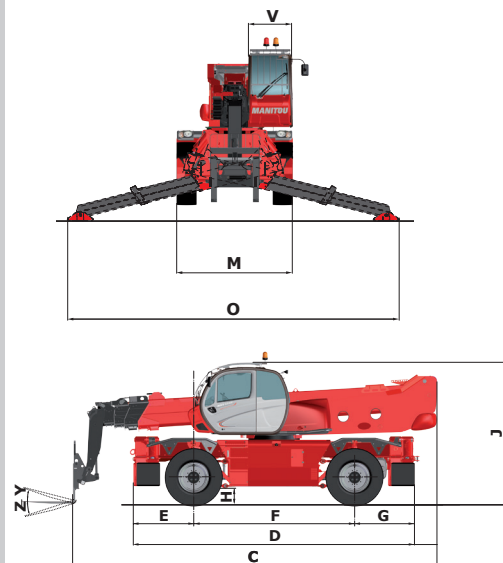

MAXIMUM FORWARD
REACH UP TO
70'3" (21.4M)

ATTACHMENTS:



HANDLER LOAD CHART

MRT 2550 PRIVILEGE PLUS SERIES 2 ROTATING TELESCOPIC

