

Crawler 50

Standard Features

- Ultra short (11' 2" L) for extraordinary maneuverability in tight quarters
- Narrow profile (32")
- Quick connect/removable 2 man 440 lbs capacity basket
- Independently movable jib for best maneuverability
- Fast and simple to operate
- Solid boom construction with tight tolerances for comfortable and secure ride
- Hydraulically adjustable tracks
- Non marking rubber tracks
- Greaseable boom pivot points
- Powerful track drive system
- Standard 120V electric hydraulic power pack
- Proportional controls for smooth operation
- Internet connectible monitoring and upgradable system
- 120V electrical outlet in platform
- Air/water hose inside boom
- 1/2/5 year warranty (see warranty statement)
- Hour meter
- High quality four coat paint process
- Durable and easy to service Honda gas engine



Crawler 50

Technical Specifications

Working height	49' 8"
Height to bottom of basket	42'
Lateral reach with 440 lbs	23'
Length in travel position (without basket)	11' 2"
Length in travel position (with basket)	13' 6"
Width in travel position (without basket)	32½"
Height in travel position	77½"
Standard basket dimensions	48" L x 28" W x 43" H
Single/variable proportional/ engine adjustable drive speed	0 – 1.5 mph
Turret rotation	359 degrees
Maximum recommended slope travel	17 degrees slope, 32% gradeability
Maximum PSI under tracks	7.26 PSI
Maximum PSI under outriggers (with max basket load/worst position)	91.3 PSI
Maximum PSI under outriggers (with standard 18" x 18" pad)	7.97 PSI
Maximum basket capacity	440 lbs
Standard footprint	8' 10" x 8' 10"
Adjustable track width	32" – 44"
Total weight	3,660 lbs

POWER

Honda GX-390 air cooled gas engine	13 hp
Electric motor	120V 20A 2.2 KW

Technical data subject to change



**ALL ACCESS
EQUIPMENT**
CRAWLER LIFTS

Reach Diagram

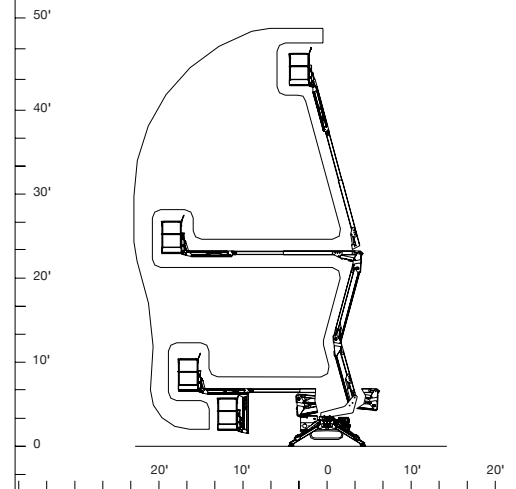

Travel Position Diagram (without basket)

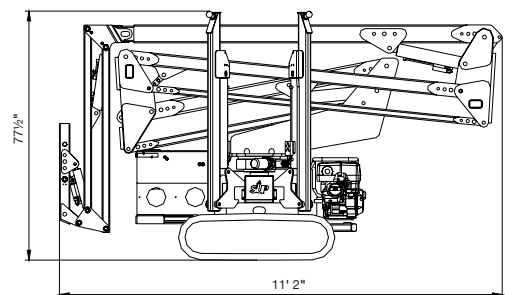

side view

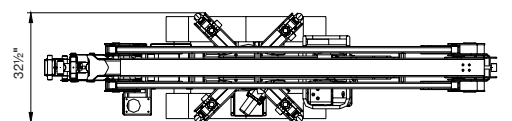

top view

Stability Diagram

